

KUDOS USA DIES 500HE FOR HYCP-500HE

■ For HYCP-500HE

- Hex Dies for Copper & Aluminum Conductors
Suitable for JIS C2804 terminals

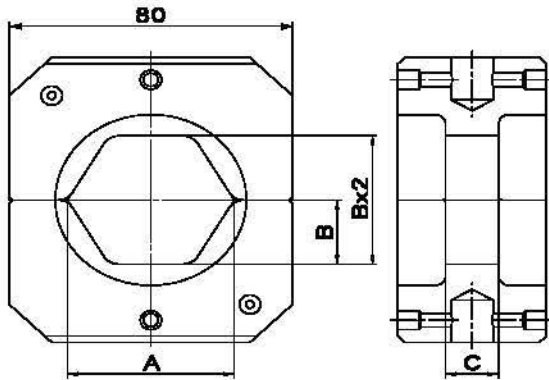

Unit : mm

Die No.	A	B	C
500HE-160AI	28.75	12.70	50
500HE-150CU	32.56	14.10	30
500HE-400CU	33.14	14.35	30
500HE-500CU	36.72	15.90	30
500HE-500AI	52.20	22.85	50
500HE-800AI	56.80	24.85	50



FOR STEEL SLEEVE

C : Die Width

Die No.	A	B	C
500HE-S17.4	17.40mm	7.53mm	42mm
500HE-S18.5	18.50mm	8.01mm	42mm
500HE-S21	21mm	8.74mm	12mm

FOR ALUMINUM SLEEVE

C : Die Width

Die No.	A	B	C
500HE-L37	37mm	16.02mm	42mm
500HE-L46	46mm	19.92mm	42mm
500HE-L54	54mm	22.95mm	42mm

■ For HYCP-60ST / HYCP-60D DIES

(image and figure for reference only)

KUDOS USA DIES FOR HYCP-60ST, HYCP-60D

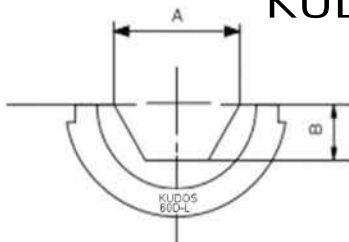

FOR STEEL SLEEVE

unit: mm

DIE NO.	A	B	C
60G-14	13.90	5.95	37.10
60G-16	15.85	6.80	33.10
60G-18	17.90	7.60	29.40
60G-20	19.80	8.60	30.20
60G-22	21.80	9.25	23.10
60G-24	23.90	10.25	22.10
60G-26	25.85	11.00	20.10
60G-28	27.65	11.80	20.10
60G-30	29.70	12.70	20.20

FOR ALUMINUM SLEEVE

unit: mm

DIE NO.	A	B	C
60L-21	21.00	9.00	19.00
60L-28.62	28.62	12.00	43.00
60L-31.77	31.77	13.13	57.00
60L-32	31.35	13.60	59.00
60L-34	33.45	14.40	58.20
60L-36	35.40	15.20	55.10
60L-38	37.35	16.10	51.90
60L-40	39.40	17.00	49.30
60L-42	41.90	17.90	46.90
60L-45	44.30	19.20	44.10
60L-48	47.25	20.45	41.10
60L-50	49.20	21.30	40.20
60L-52	51.25	22.10	37.40
60L-55	54.25	23.45	39.75